

# CenterVac Central Loading Systems

# Weighbatch

Material Handling & Gravimetric Control

Centralise Your Material Handling !

Reduce Maintenance Costs & Time !

High Utilisation from High Reliability !

Simplifies Operation !

Fully Automated Systems



Vacuum pump



Group of different size vacuum loaders



Filter & Controller

## Features:

- Central Start/Stop and full control of all loaders and pumps from single operator console, local loader controls, automatic and manual pump control
- Pump protection filter plus central filter with dust collector, electronic vacuum sensors , replaceable cartridge filters elements, automated pulse cleaning and removable dust bowl
- Automatic detection and alarm indication if full load not delivered to processing machine giving early warning of material supply issue
- Filter clean times and vacuum levels set to maximise throughput and efficiency
- Stand alone system OR fully integrated with Weighbatch AdvanTec central control system

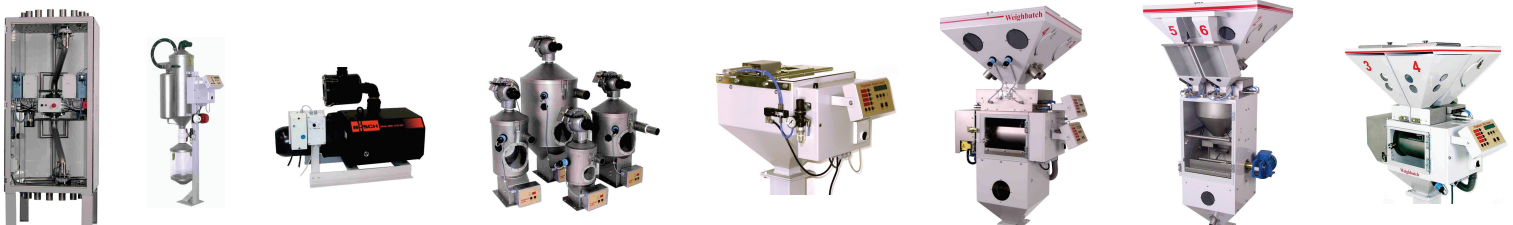

# CenterVac Central Loading Diagrams

## Weighbatch

Material Handling & Gravimetric Control

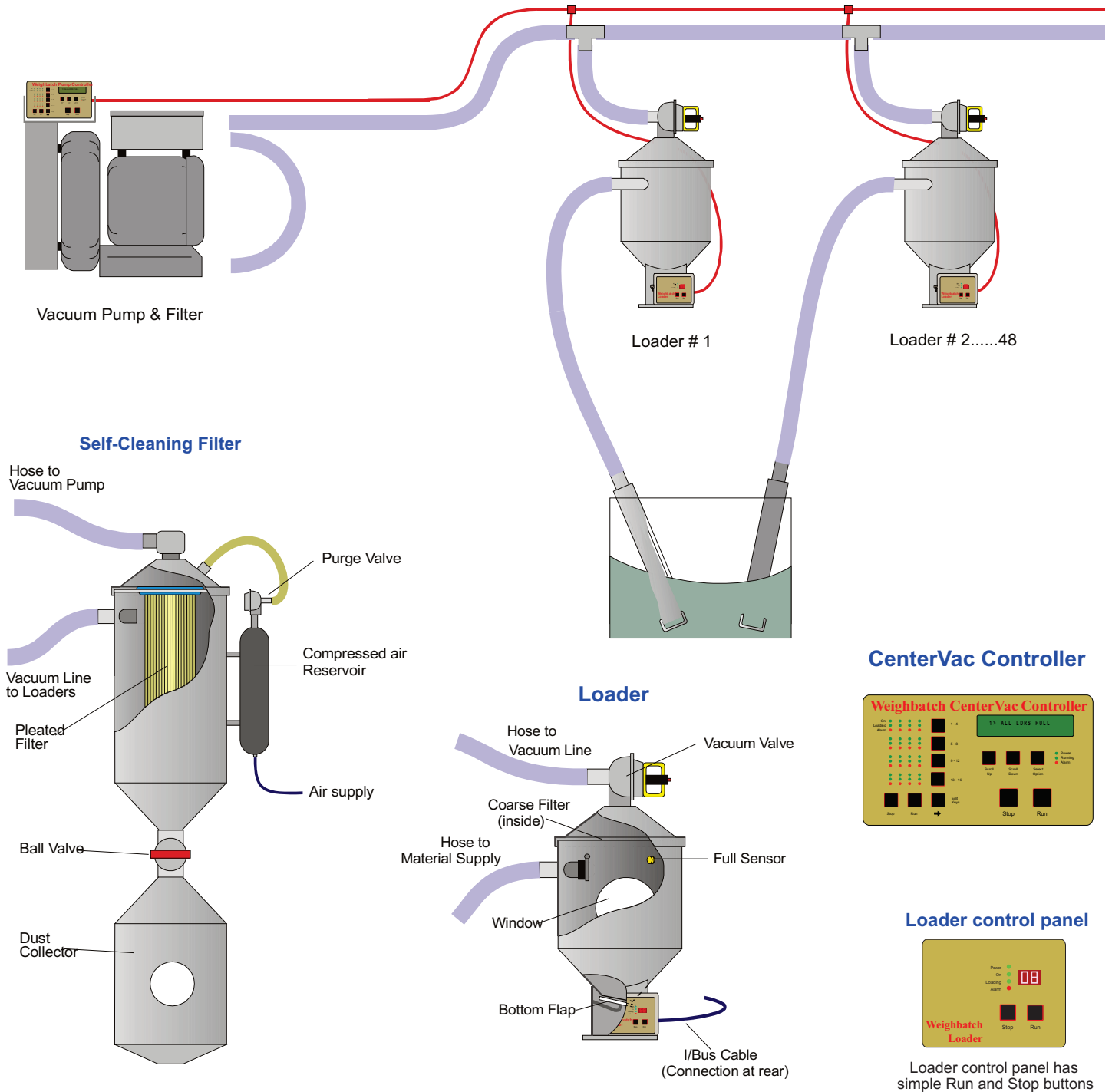

### Specifications:

- CenterVac Loaders 200, 250, 320 & 500 mm body
- Rotary lobe or side channel blower vacuum pump
- Dynamic and static parts in contact with material are stainless steel
- Standard Controller suitable for up to 16 loaders, extendable to 32 & 48 for larger applications
- Power supply 1 Ph 230V & 3 Ph 415V 50 Hz
- Pneumatic air supply 6 bar, regulator supplied

### Options:

- Fabric filter with automatic blow back filter cleaning
- Dual port loader to effect proportional loading, proportional valves also available
- Remote mounted operator controls/display
- High capacity filter for high dust levels
- Big Foot loaders for regrind
- Back up and/or dual pump system